

Assembly instructions

Clip type B2

Under head for welding

Commission
 Task no.: 100000.....

Easy Hang GmbH
 Lange Morgen 5
 D 72768 Reutlingen
 Tel. +49(0) 7121 479240
 Fax. +49(0) 7121 479241

EASY HANG
 Flex strip curtain
 03/2007

Fixing and fastening the welding plate begins with an interval of approx. 100mm and then continuing in the interval of approx. 1000mm by screwing the alu-profile rail to the plate

The alu-profile rail is screwed on completely or in lengths using the welding plates welded to the structure.

The PVC strips are measurement of 20mm. manufactured with a negative After a few days in heated chambers the strips elongate. After a longer period of time, the PVC strips can have elongated so far, that they stand up on the ground. The strips can be cut simply by using the blade provided.

To suspend the PVC strips, the clip is set with an angle of approx. 40° to the profile rail and clipped on to the rail using a plastic hammer.

The suspension of the PVC strips occurs by cancelling the single clip from the alu-profile rail with an angle of approx. 30°

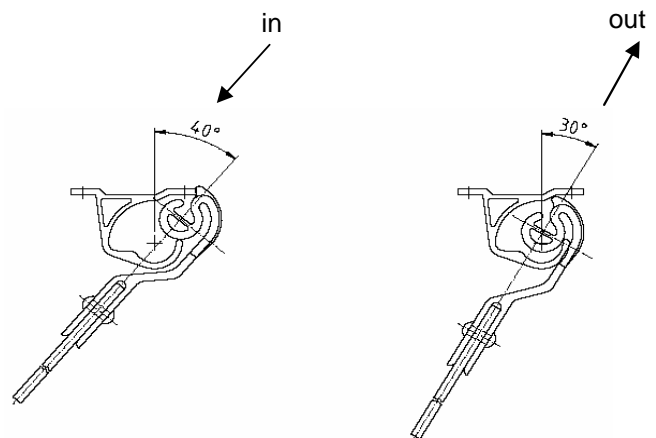
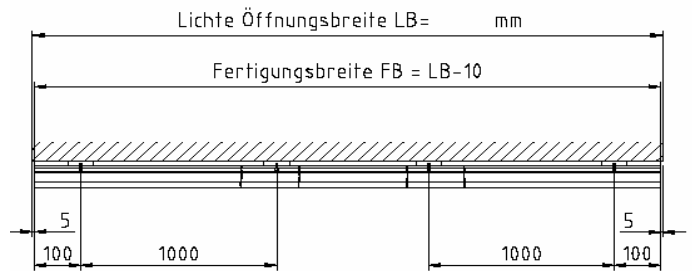
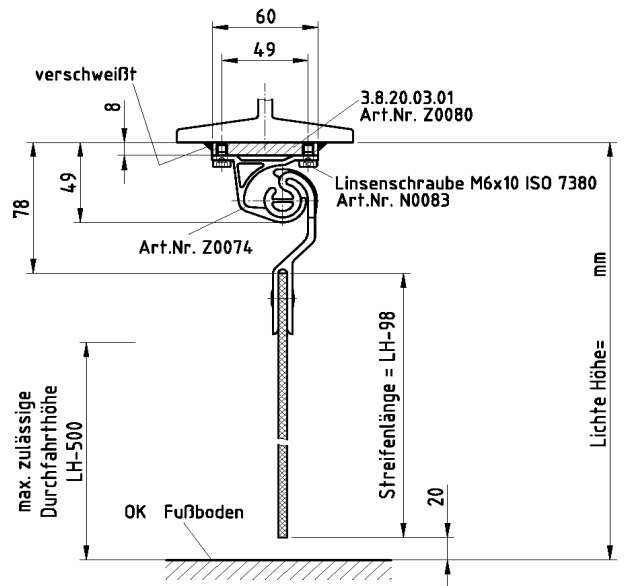

Assembly instructions

Clip type B2

Weight per metre. 3.6kg



Under head for welding

Commission

Flex strip curtain

Task no.: 100000.....

03/2007

Strip type
 200mm wide x 2mm thick, length mm

Part total number of strips
 Of which concave parts with a red point

Strip type
 300mm wide x 3mm thick, length mm

Part total number of strips
 Of which concave parts with a red point

Strip type
 400mm wide x 4mm thick, length mm

Part total number of strips
 Of which concave parts with a red point

Firstly suspend all concave strips beginning on the left (with red point) in the profile rail.
 Afterwards hang the covering strips according to overlap over the concave strips (convex).

at places with the gap is with an empty clip closed

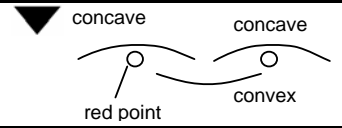

Art. no.	Part list B2	Part	Length mm			
Z0074	Alu-profile rail 60mm					
Z0080	Fastening plate					
N0007	Stop screw 3.5x16					
N0083	Oval-head screw with hexagon socket M6x10 ISO 7380					
K0108	Empty clip colour orange					
Z0026	Riveted clip					
K0016	Blade					
K0034	Packaging pallet					
	Collar					